

Specifications

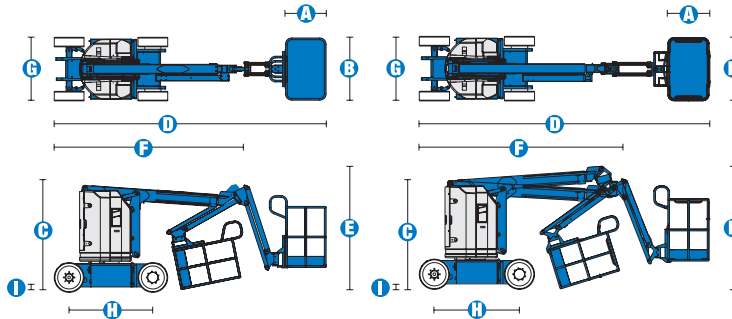

MODELS	Z™-30/20N		Z™-30/20N RJ	
MEASUREMENTS	US	Metric	US	Metric
Working height maximum*	36 ft	11.14 m	35 ft 2 in	10.89 m
Platform height maximum	30 ft	9.14 m	29 ft 2 in	8.89 m
Horizontal reach maximum	21 ft 5 in	6.53 m	20 ft 6 in	6.25 m
Up and over clearance maximum	12 ft 8 in	3.86 m	12 ft 8 in	3.86 m
A Platform length	2 ft 6 in	.76 m	2 ft 6 in	.76 m
B Platform width	3 ft 10 in	1.17 m	3 ft 10 in	1.17 m
C Height - stowed	6 ft 6.5 in	2 m	6 ft 6.5 in	2 m
D Length - stowed	16 ft 9 in	5.11 m	17 ft 5 in	5.31 m
E Storage height	6 ft 10 in	2.08 m	7 ft 4 in	2.24 m
F Storage length	11 ft 6 in	3.5 m	12 ft	3.66 m
G Width	3 ft 11 in	1.19 m	3 ft 11 in	1.19 m
H Wheelbase	5 ft 3 in	1.60 m	5 ft 3 in	1.60 m
I Ground clearance - center	3.5 in	.09 m	3.5 in	.09 m

PRODUCTIVITY	Z™-30/20N		Z™-30/20N RJ	
Lift capacity	500 lbs	227 kg	500 lbs	227 kg
Platform rotation	180°		180°	
Vertical jib rotation	139°		139°	
Horizontal jib rotation	—		200°	
Turntable rotation	355° non-continuous		355° non-continuous	
Turntable tailswing	zero		zero	
Drive speed - stowed	3.0 mph	4.8 km/h	3.0 mph	4.8 km/h
Drive speed - raised**	0.68 mph	1.1 km/h	0.68 mph	1.1 km/h
Gradeability - stowed***	35%		35%	
Turning radius - inside	5 ft 5 in	1.65 m	5 ft 5 in	1.65 m
Turning radius - outside	10 ft 7 in	3.23 m	10 ft 7 in	3.23 m
Controls	24 V DC proportional		24 V DC proportional	
Tires - solid non-marking	22x7x17.75 in	.56x.18x.45 m	22x7x17.75 in	.56x.18x.45 m

POWER	Z™-30/20N		Z™-30/20N RJ	
Power source	48 V DC (eight 6 V batteries 350 Ah capacity)		48 V DC (eight 6 V batteries 350 Ah capacity)	
Auxiliary power unit	24 V DC		24 V DC	
Hydraulic tank capacity	4 gal	15.1 L	4 gal	15.1 L

WEIGHT****	Z™-30/20N		Z™-30/20N RJ	
	14,170 lbs	6,427 kg	14,220 lbs	6,450 kg

STANDARDS COMPLIANCE ANSI A92.5, CSA B354.4, CE Compliance, AS 1418.10, PB-10-611-03

* The metric equivalent of working height adds 2 m to platform height. U.S. adds 6 ft to platform height.
 ** In lift mode *(platform raised), the machine is designed to operated on firm, level surfaces only.
 *** Gradeability applies to driving on slopes. See operator's manual for details regarding slope ratings.
 **** Weight will vary depending on options and/or country standards.

RANGE OF MOTION Z™-30/20N

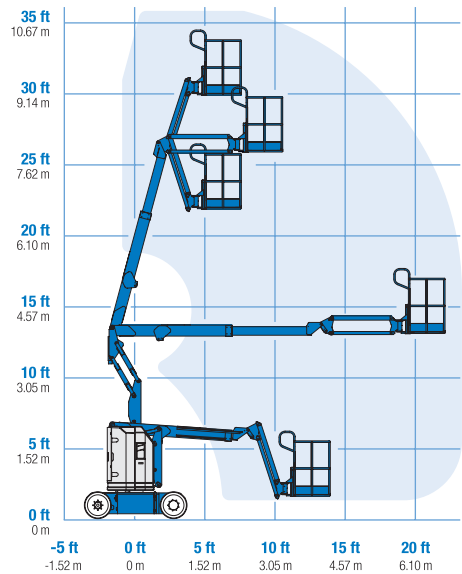

RANGE OF MOTION Z™-30/20N RJ

